



WARBIRDKITS.COM

Assembly Manual for

Messerschmitt Bf 109F-2

Version 2 – 4 November 2005



Designed by Terry Majewski

Materials

Kit Contents

This kit includes the following items:

- Laser-cut balsa, 12 sheets
- Laser-cut plywood, 1 sheet
- Laser-cut elevator horn, 1 each
- 6" x 6" Clear plastic canopy material, 1 sheet
- Construction manual, 1 each
- Decals, 1 sheet

Builder-Provided Materials

You will need to provide the following materials to complete this kit:

- 1/16" x 4" x 15" Balsa, 4 sheets
- 1/8" x 1" Dowel, 1 each
- 1/4" x 12" Balsa triangle, 2 each
- 3/8" x 6" Balsa triangle, 1 each
- 1/16" x 12" Music wire, 1 each
- 3/32" x 9" Aluminum tubing, 1 each
- 1-3/4" Du-Bro spinner
- Aileron linkage (suggest Du-Bro Cat No 189 Aileron Horn Wire Ball Links)

- Elevator pushrod and quick-link
- Hinges (ailerons, elevators)
- Glue, covering and paint
- 2 ounce Fiberglass cloth (wing reinforcement)
- 0.56 ounce Fiberglass cloth (spinner reinforcement)
- Pair of super-magnets or bolt and nut (hatch hold-down)
- Motor, propeller and battery
- Radio gear: receiver, elevator servo, aileron servo

Power

The prototype was powered by a Mega 16/15/5 brushless motor, an 8 cell 1100 mAh NiMh battery, and an APC 7x5e prop.

If built light (17 to 18 ounces) a Speed 400 motor should provide sufficient power.

Updates and Free Downloads

Please visit our Web site www.warbirdkits.com for product updates and free downloads!

Construction

Wing

The wing is a fully-sheeted spar-less design that achieves strength without unnecessary weight. The wing is designed to be permanently attached to the model's fuselage for structural integrity.

The wing consists of two panels: port and starboard. Each panel has a top skin and a bottom skin.

Wing Skins

- Each lower wing skin consists of two laser-cut and etched pieces: forward and aft. Gently clean up the mating edges of the skin pieces with 220 grit paper on a sanding block.
- Lay the two pieces of a wing skin on a flat board or table, with the outer surface up. Run a length of masking tape along the join line. Turn the assembled skin over, bend the joint open, and run a bead of wood glue down the joint.
- Lay the assembled skin back down on the flat board – masking tape side down. Run a damp paper towel over the joint to remove excess glue. Place a sheet of wax paper over the assembled skin. Then weight it down with another board, books or what have you. Keep the weight on the skin until it is completely dry.
- While waiting for the bottom skins to dry, prepare the top skin material as follows. For each top skin,

join two sheets of 1/16" x 4" balsa using the tape and glue method above.

- When the bottom skins are dry, remove the masking tape from the joints.

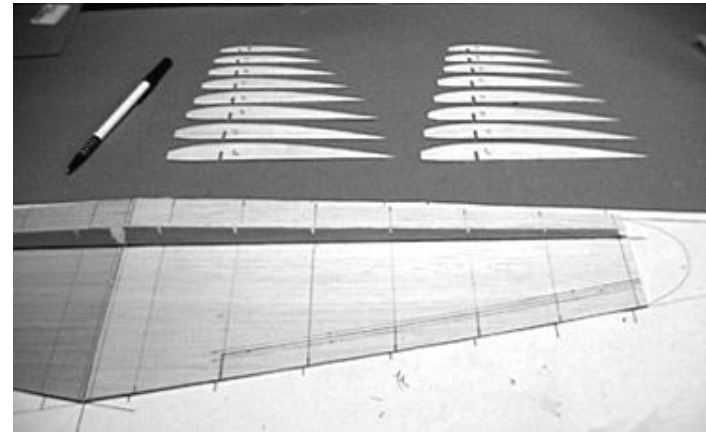

- Trace the outlines of the bottom skins onto the top skin material. Then cut out the top skins leaving about 1/8" extra material at the trailing edges.
 - Sand each skin as follows. Lay a skin on a flat board with the outer surface up, and sand it smooth with 120 grit paper on a long sanding block. Be sure to keep your sanding motion at a 45-degree angle to the joints and wood grain. Clean the skin with a tack rag.
- Note** – it should not be necessary to sand the inner surfaces of the wing skins. Just be sure to remove any excess glue.

Wing Panels

- Pin a lower wing skin to your building board. (The lower skins are the ones with the rib and aileron hinge strip positions etched into them.)

NOTE: Ignore the wing main spar in the construction photos.

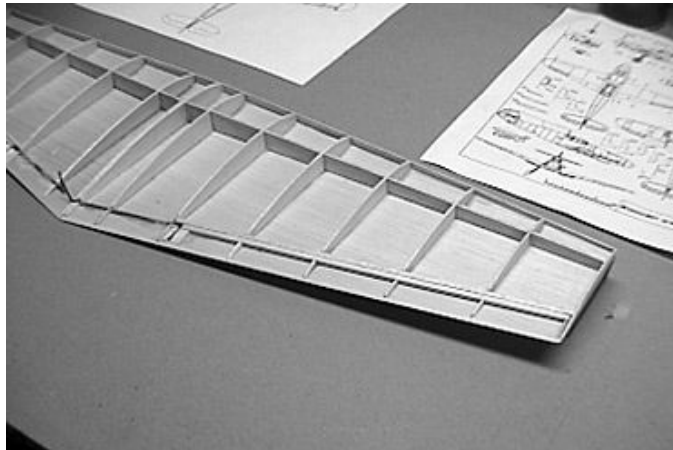

- Use the laser-cut dihedral gauge to set the root rib in position. When satisfied with the fit, glue it to the bottom skin.
- Glue the rest of ribs to the bottom skin. Glue the aileron hinge strips to the ribs and bottom skin, one on either side of the laser-cut separation line. DON'T glue the aileron hinge strips together.

NOTE: Use scrap 3/32" material to pack the leading edge of the bottom skin up so that it is in contact with the full length of each rib.

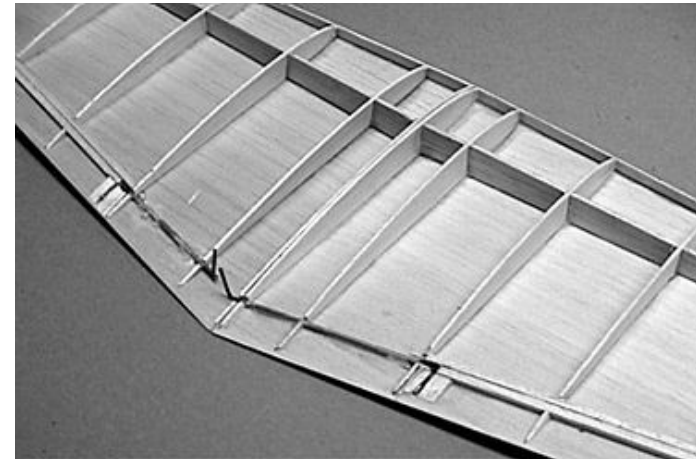

- Fabricate aileron torque rods from 3/32" aluminum tubing and 1/16" music wire.
- Glue torque rod tubing to the bottom skin BUT NOT to the aileron. Glue blocks on either side of the aileron crank. Do not cut the aileron out at this time.

- Glue the 1/16" sub-leading edge to the front of the ribs.

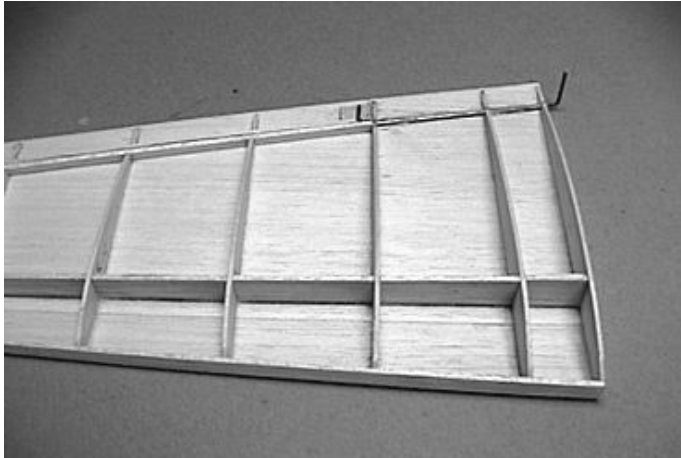

- Sand the wing panel structure so that the aileron hinge strips and crank blocks match the wing rib contour. Sand the top of the trailing edge so that it tapers to about 1/32" width. This provides a gluing surface at the trailing edge for the top skin.
- Pin a wing panel to the building board, using the laser-cut washout jigs to establish 1/8" wingtip washout.
- Glue the 1/16" top skin to the wing panel structure. Let the glue cure thoroughly before unpinning the wing panel from the building board.
- **NOTE** – The laser-cut 1/8" leading edge strip is not wide enough to cover the entire leading edge. To remedy this, simply cut a 1/8" inch wide strip from

the excess 1/8" sheet and edge-glue it to the laser-cut leading edge.

Glue the 1/8" laser-cut leading edge to the wing panel.

- Glue the laser-cut wingtip to the tip rib. **NOTE** – laminate a scrap of 1/16" sheet to the top of the wingtip block.
- Shape the leading edge and wingtip of each wing panel to the shapes shown on the plans.

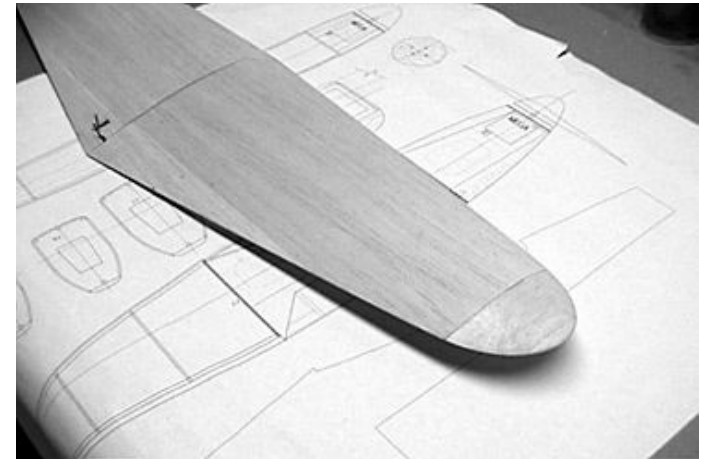

- Prepare to join the wing panels by pinning one wing panel, with its washout jigs, to your building board. Jig the other wing panel so that its center rib matches the center rib on the pinned-down panel, and raise its wingtip 2" above the building board.

- Glue the panels together. We suggest 15-minute epoxy for this joint.
- Wrap the center section of the assembled wing with a strip of 2.6oz fiberglass cloth. Soak the cloth with thin CA glue.

- Cut the ailerons free from the completed wing.

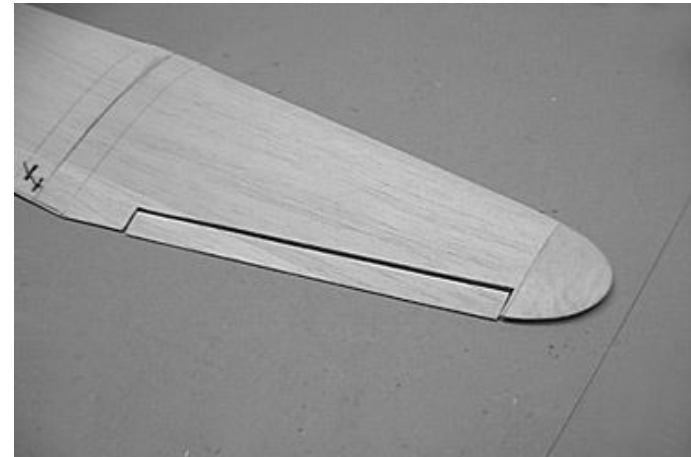

- Bevel the aileron leading edges slightly to allow for 3/16" movement both up and down.
- Hinge the ailerons to the wing.

- Install the aileron servo and linkage in the wing.

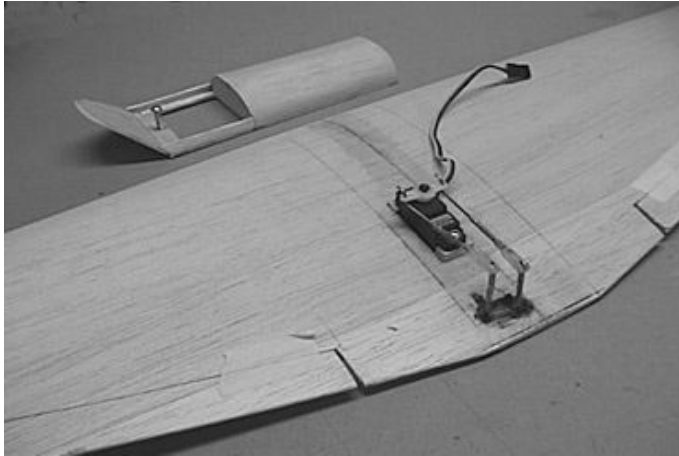

Fuselage

- First, determine how many spacer rings you'll need for your motor, prop adapter and spinner combination. Attach your motor to the plywood firewall F1. Then set up the prop adapter and spinner as they'll be on the finished model. Adjust the number of spacer rings until you get a nice fit between the spinner and the spacer – about 1/16" is fine.
- Glue the 1/16" balsa doublers to the fuselage sides. Be sure to make a left and right side!

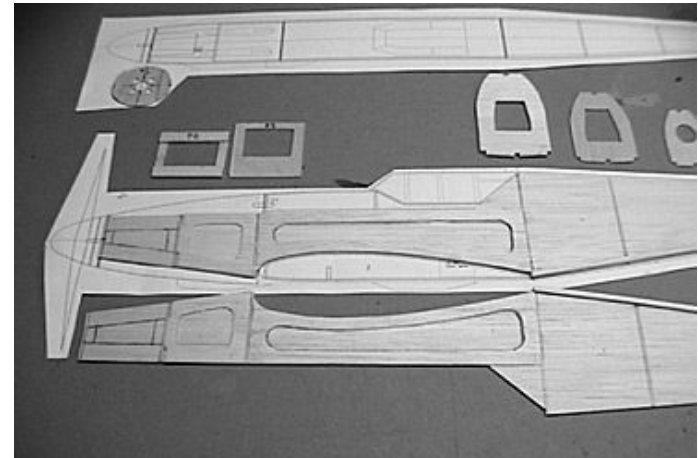

- Glue a 1/8" sq. balsa strip along the lower edge of the fuselage side from F4 to F7.

- Glue F2, F3 and F4 to one fuselage side making sure they are aligned 90 degrees. Then glue to the other side.

NOTE: Dab a weak solution of household ammonia on the fuselage sides to make them bend easily.

- Pull the tail together and place formers F5, F6 and F7 in place. Secure the lower part of the formers to the fuse sides with thin CA.

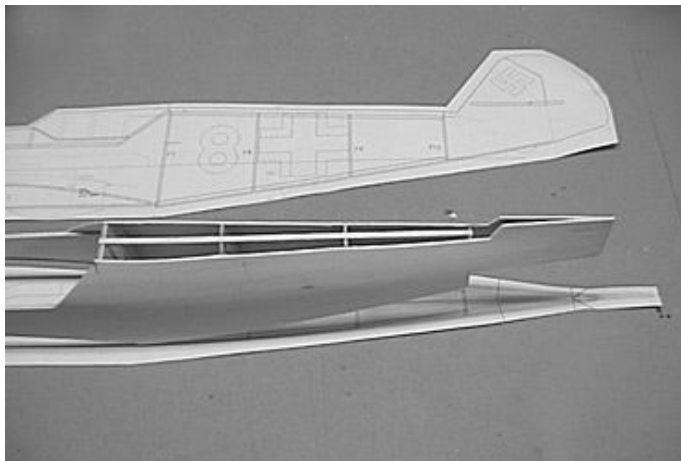

- Glue the plywood firewall F1 in place.
- Glue a 1/8" square balsa stringer to the top of the rear formers.

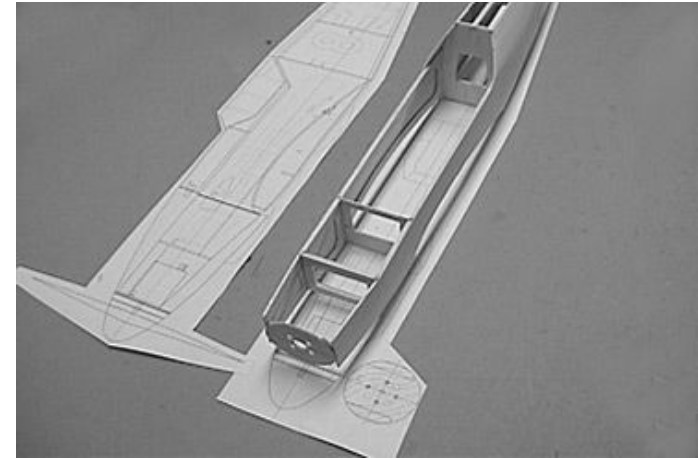

- Moisten the top half of the fuselage sides and gently press them against the top portion of formers F4, F5, F6, and F7. Secure with thin CA.

- Add the 1/8" balsa stringer to the lower rear fuselage.

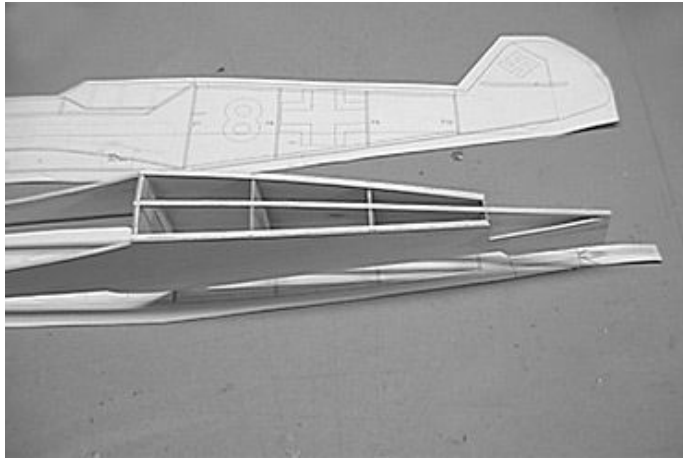

- Add 1/4" balsa blocking to the forward fuselage to allow for sanding to a rounded shape.
- Glue 1/4" balsa triangle strips to the top of the fuselage sides aft of the firewall F1 to provide more material for shaping the nose.

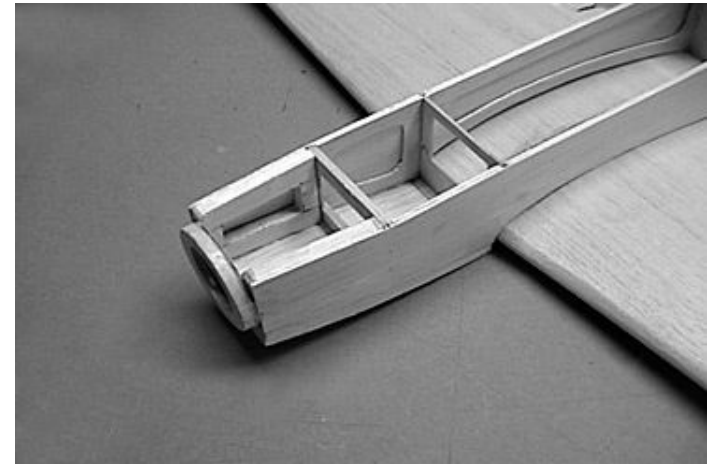

- Glue the two 1/4" balsa bottom blocks together, then glue them to the bottom of the forward fuselage.
- Glue the appropriate number and size spacer rings to the forward fuselage. Use your motor and spinner combination to select the correct spacer rings.

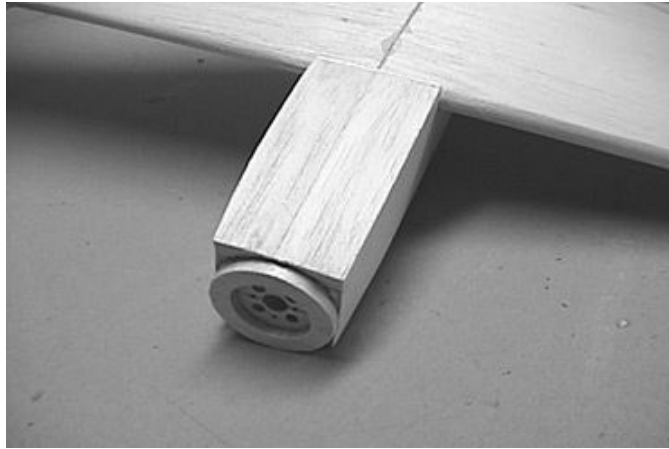

- Glue the two 1/4" balsa top blocks together, then glue them to the top of the forward fuselage.
- Install a temporary spinner to aid in final sanding of the forward fuselage. Sand the nose to shape.

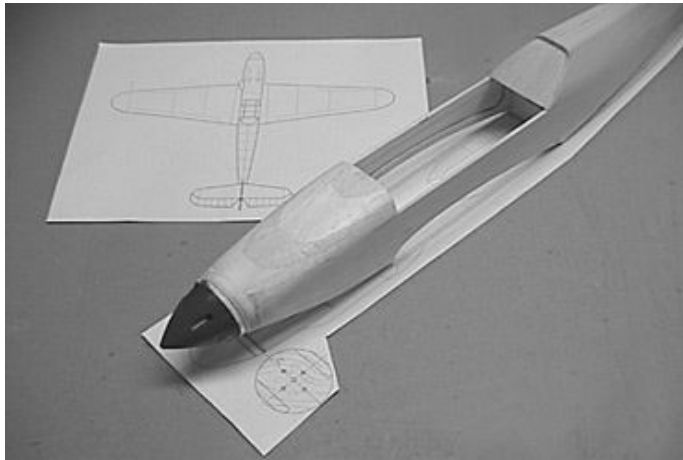

- Sheet the bottom of the fuselage with 1/16" balsa. In this photo, the sheeting is not complete.

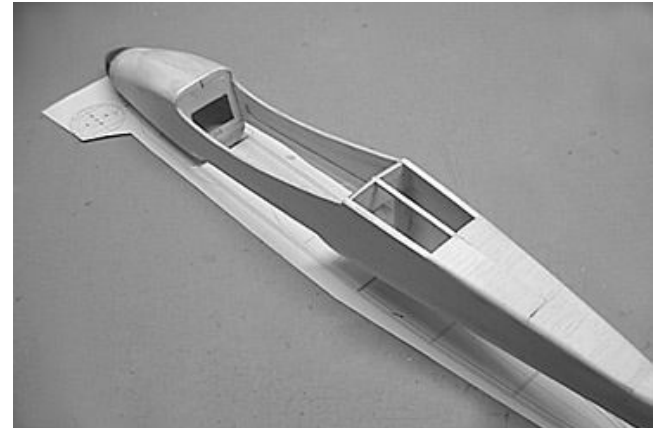

- Glue the 1/4" balsa top block in place on the rear of the fuselage. Sand it to a symmetrical rounded shape.

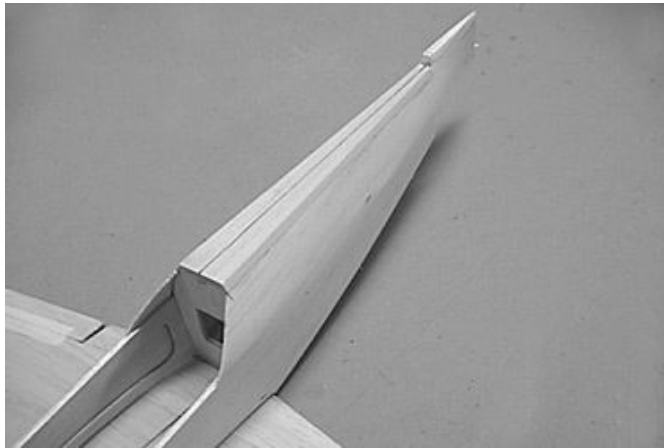

- Trim the trailing edge of the wing at the center. Test fit the wing to the partially completed fuselage. Adjust the wing saddle as needed.
- Glue the wing to the fuselage. We recommend epoxy for this critical join.

- Begin the cockpit hatch by constructing a 1/16" x 1/4" balsa frame (2 layers). The rear cross piece is two layers of 1/16" ply (for the hatch screw support).
- Glue formers F3T and F4T to the hatch frame and add a 1/8" balsa stringer between them.

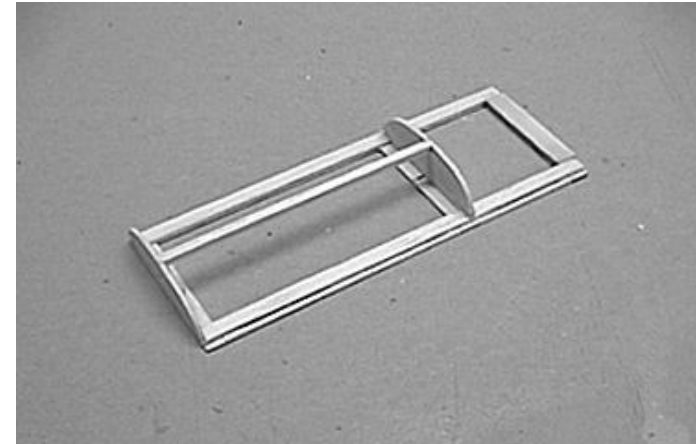

- Sheet the hatch with two pieces of 1/16" balsa.

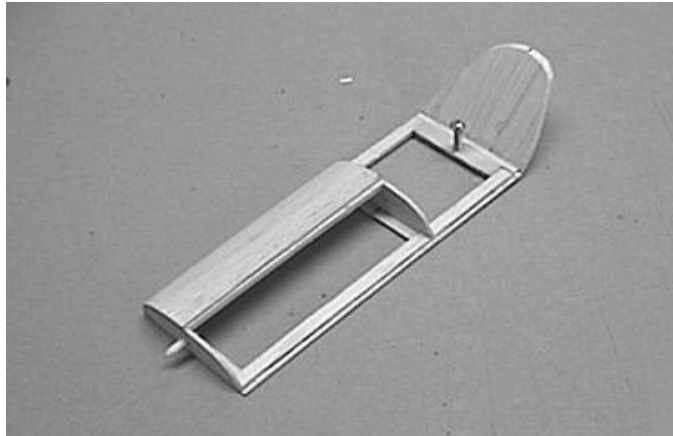

- Place the hatch on the fuselage temporarily. Using a piece of wax paper to keep it from sticking to the fuselage, glue the cockpit rear bulkhead to the hatch frame.
- Place the hatch on the fuselage temporarily. Using a piece of wax paper to keep it from sticking to the fuselage, glue the cockpit rear bulkhead to the hatch frame.
- Glue a 1/4" x 1/16" balsa strip between the rear bulkhead and F4T.
- Per the plan, use a bolt and blind nut to attach the hatch to the model. Or use super-magnets in place of the bolt and nut.

- The finished hatch should look like this.

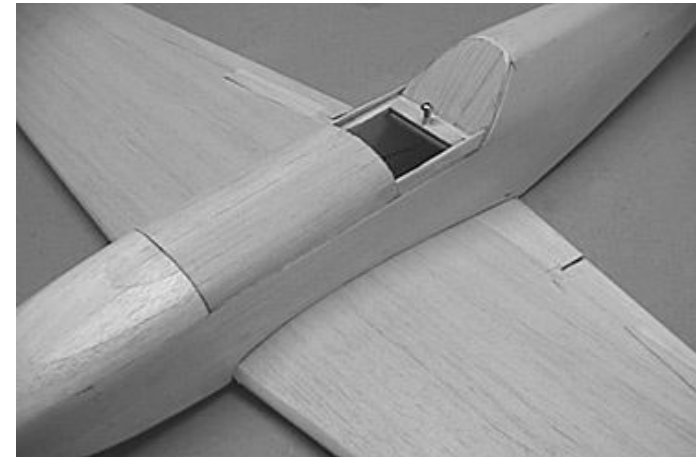

Empennage

- Glue the rudder pieces together and sand smooth.
- Make an elevator joiner from a length of 1/16" music wire.
- Hinge the joined elevators to the horizontal stab.

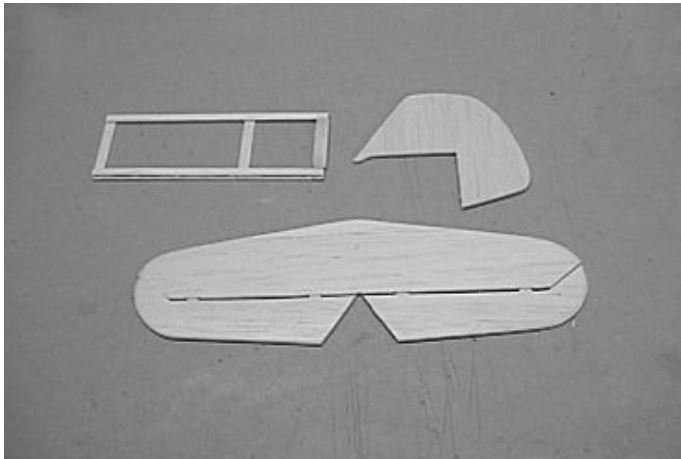

- Glue strips of 1/4" balsa triangle stock to the fuselage to create a platform for the horizontal stabilizer.



- Align the horizontal stabilizer to the fuselage making sure it is level with the wing tips. Then glue the horizontal stabilizer to the fuselage.

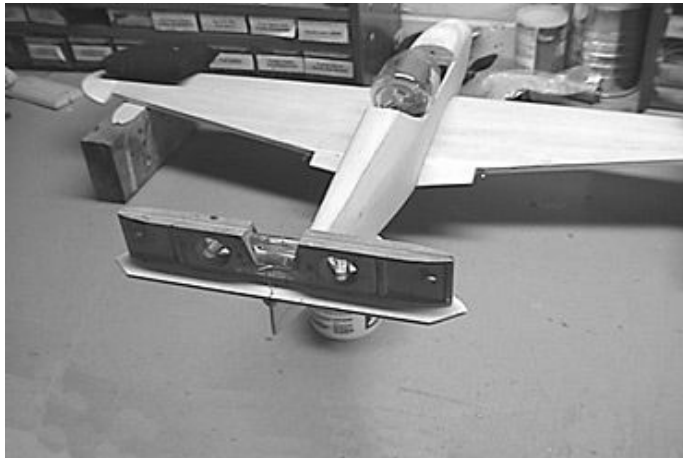

- Sand the 1/4" triangle horizontal stab platform to a concave shape. Then reinforce the stab-fuselage joint with a strip of 0.56 ounce fiberglass cloth and CA.

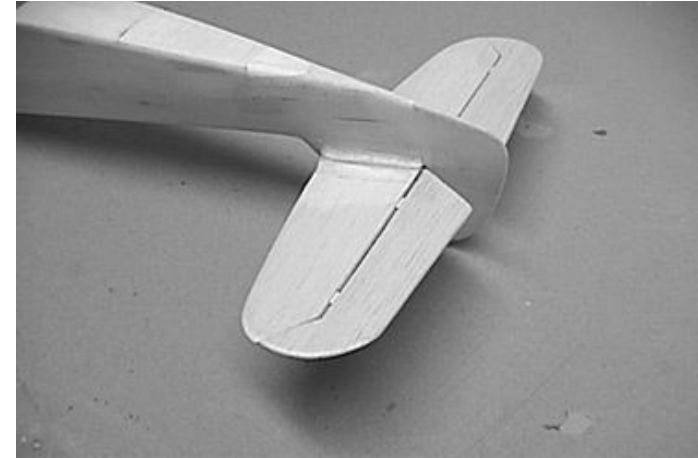

- Insert the vertical stabilizer/rudder assembly tabs into the slots in the horizontal stabilizer. Make sure that the vertical stabilizer is aligned correctly. Then glue it in place.

Detailing Your Model

- Prepare two lengths of 1/4" balsa triangle for the wing fillets. Use a razor saw to slice the triangle stock about every quarter-inch. These slices will help the triangle stock conform to the wing's top surface.
- Glue the fillets in place between the wing and fuselage.
- Fill the slices and gaps with lightweight balsa filler. Then sand a concave shape into the fillets.

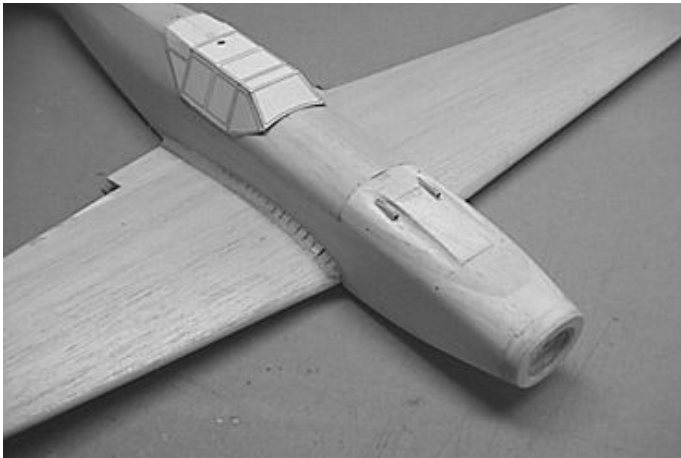

- Use a sharpened 1/4" diameter brass tube in a Dremel™ tool to dig the gun troughs. Install 1/8" tube "guns".
- Glue the three radiators together and attach them to the wing and fuselage.

- Add a small sheet balsa fairing to the underside of the fuselage, above the wing leading edge.



- Using the template provided, cut a paper canopy and fit it to the model. When satisfied with the fit, transfer the pattern to the clear plastic sheet. Cut out the clear plastic canopy and glue it in place.
- Add the desired scale details, such as exhausts, air scoop, etc.



- Details on how to make a scale spinner are included at the end of this manual. This model needs a rounded spinner – the commercially-available “pointy” spinners just don’t look right!

Finishing Your Model

- We suggest covering the entire model (except the canopy) with 1/2-ounce glass cloth and finishing resin for maximum strength.
- Apply a light coat of primer – just enough to fill the weave of the glass – and sand most of it off.
- Paint and decorate the model as desired. See the attached 3-view for details on markings and panel lines.
- Finally, seal the entire model with a coat of Krylon Satin Crystal Clear.

Decals

CAUTION: You must seal the decals before immersing them in water!

The decals included in this kit are printed with Epson DuraBrite™ inks on the best inkjet water-slide decal paper available. Follow the steps below to achieve a great looking set of markings on your *Friedrich*.

- Seal the decals with several thin coats of Krylon Crystal Clear™ spray varnish. Make sure you thoroughly cover the ink; this will prevent smears and stains during everyday handling.
- Make sure the surface where the decal is to be applied is smooth and glossy. Matte surfaces will permit tiny air bubbles to be trapped between the surface and the decal, thus spoiling the decal.

- ❑ Cut out and trim all the markings that you plan to apply in this session.
- ❑ Dip the decal in a bowl of warm water for about 20 seconds. Using your fingers, **gently** try to slide the decal off the backing paper. As soon as the decal slides, slide it off the backing paper and onto the model in the desired position. Use a rag or old t-shirt to gently blot excess water from the decal. Allow the decal to dry.
TIP – If you leave the decal in the water too long, the ink will run. Practice with bits of decal cut from the copyright notice.
- ❑ If you ruin your set of decals, you can download a set from www.warbirdkits.com. Print them on self-adhesive label material or decal material.

Alternative Color Schemes and Markings

This kit will build into many different marks of Bf 109, including the F, G and K, so there are literally thousands of different color schemes and markings available.

Visit the Bf 109 page at www.warbirdkits.com to download some alternative markings and extra scale details. You can download a full set of markings for a G model flown by Hans-Joachim Marseille and a G model flown by the Finnish Air Force, absolutely FREE for non-commercial use.

Weight and Balance

- ❑ The prototype weighed in at 20.5 ounces ready to fly. A range of 17 to 21 ounces all up weight should result in a great-flying model.
- ❑ The Bf 109 should balance as shown on the plans. For the first few flights, you may want to move the balance point forward about 1/4" - better a bit nose-heavy than a bit tail-heavy!

HELP!

If you have questions or need more help with assembly of the Messerschmitt Bf 109F-2 kit, drop an email to tom@warbirdkits.com.

Bf 109F-2 flown by Leutnant Max-Hellmut Ostermann, 7./JG 54, Russia, October 1941 (Prototype by Terry Majewski)



Bf 109F-4/Trop flown by Oberleutnant Hans-Joachim Marseille, 3./JG 27, Egypt, September 15, 1942 (Model by Tom Jacoby)

